

Kunststoffventilator PC

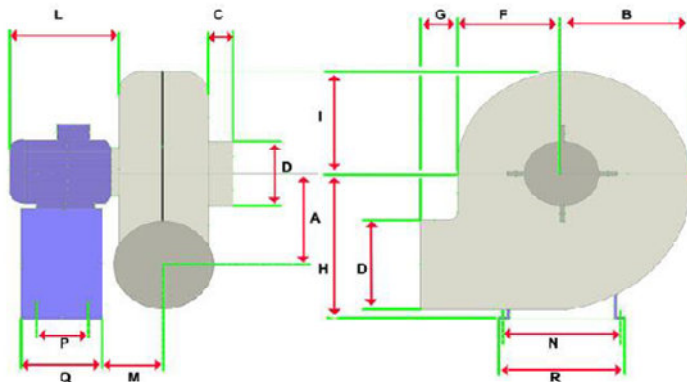

Tipo	Mot.Gr Size	Mot KW	Giri RPM	A	B	C	Ø	E	F	G	H	I	L	N	P	Q	R	S	KG.*	KG.**
PC 204	63	0.12	1400	142	187	40	125	108	150	60	250	165	183	200	100	140	235	11	18	
PC 202	63	0.25	2750																	
PC 254	63	0.18	1400	183	225	40	160	140	170	80	310	210	183	255	100	140	290	11	21	
PC 252	80	0.75	2850										225							
PC 284	63	0.18	1400	208	255	40	180	150	185	80	350	230	183	277	120	190	320	11	26	
PC 282	80	1.10	2850										225							
PC 316	63	0.12	930	240	275	40	200	155	205	80	410	245	183	320	150	230	355	11	33	
PC 314	71	0.25	1400										205							
PC 312	90	1.50	2850										260							
PC 406	71	0.25	930	290	380	40	250	185	260	80	495	330	205	330	170	250	370	11	41	
PC 404	80	0.75	1450										225							
PC 402	112	4	2850										325							

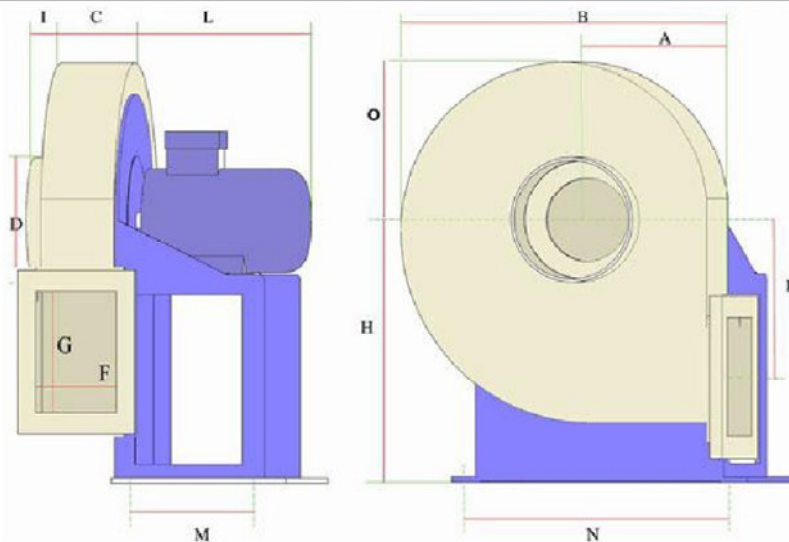

Tipo	Mot.Gr Size	Mot KW	Giri RPM	A	B	C	D	E	F	G	H	I	L	M	N	O
PC 504	100	2.2	1450	400	890	270	315	377	250	366	630	50	355	197	290	395
PC 506	90	0,75	900	400	890	270	315	377	250	366	630	50	320	197	290	395
PC 564	132	5,5	1450	438	998	320	400	416	300	466	710	50	480	237	289	445
PC 566	112	2,2	900	438	998	320	400	416	300	466	710	50	480	237	289	445
PC 634	132	7,5	1450	468	1041	340	450	406	320	462	800	50	480	237	337	492
PC 636	132	3	900	468	1041	340	450	406	320	462	800	50	480	237	337	492